



FRIDURIT® SINK ELEMENT

made of Technical Ceramics

www.kyocera-solutions.de

FRIDURIT® TECHNICAL CERAMICS SINK MODULE

The FRIDURIT laboratory sink element made of Technical Ceramics can be integrated just where access to water is required. The pleasing design enables a clear segmentation of wet areas and a differentiation to conventional sinks.

DIMENSIONS

The sink element can be adjusted in depth according to your requirements from min. 650 mm to max. 860 mm.

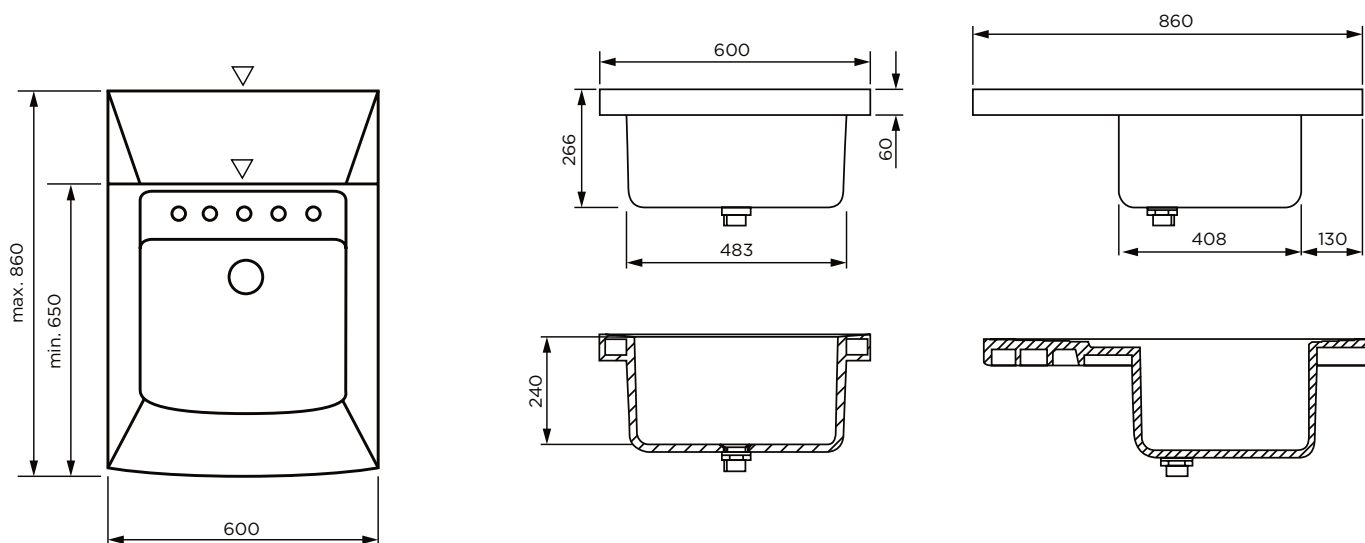

ARRANGEMENT EXAMPLES

The depth of the adjacent benchtops is flexible from 615 mm to max. 835 mm.

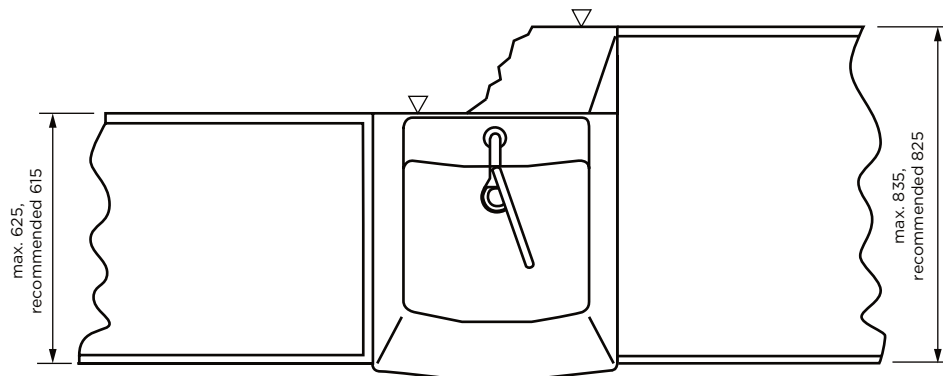

TECHNICAL CERAMICS

Laboratory work surfaces are exposed to extreme strains. FRIDURIT Technical Ceramics products are tuned optimally to the work processes in your laboratory and withstand all strains and stresses. FRIDURIT laboratory benchtops and sinks stay as good as new, even when permanently subjected to chemical influences and high thermal or mechanical stresses such as scratching, scouring and leaning processes.

Technical Ceramics is:

- ▶ easy to clean
- ▶ resistant to chemicals
- ▶ microbiologically pure
- ▶ scratch-proof
- ▶ heat resistant
- ▶ environmentally compatible

GLAZE COLOURS

FRIDURIT sink elements are available in many colours. Here you find a selection of glaze colours available. The sink module is available in plain colour glazing.

The samples shown are not binding and are only a guide to the colour of the material. Ceramic colour samples are available on request.

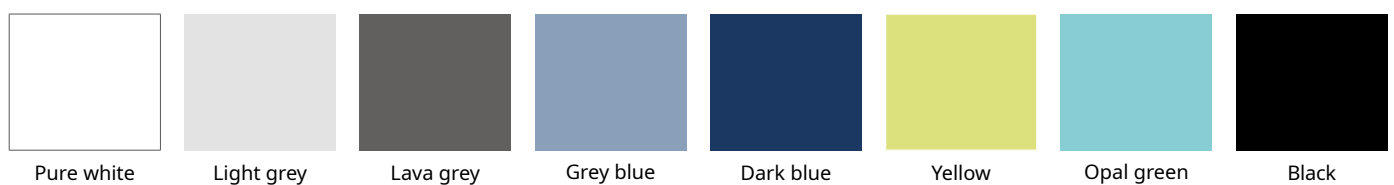



European headquarters:

KYOCERA Europe GmbH
Fritz-Müller-Strasse 27
73730 Esslingen / Germany
Tel: +49 711 93 93 4-0
E-mail: info.fc@kyocera.de
www.kyocera-fineceramics.eu

Sales office Neuss:

KYOCERA Europe GmbH
Hammfelddamm 6
41460 Neuss / Germany
Tel: +49 2131 16 37-0
E-mail: info.fc@kyocera.de
www.kyocera-fineceramics.eu

Sales office France:

KYOCERA Fineceramics SAS
Parc Icade Orly - Rungis
21 Rue de Villeneuve
94150 Rungis / France
Tel: +33 1 41 73 73-30
E-mail: sales.france@kyocera.de
www.kyocera.fr

Sales office UK:

KYOCERA Fineceramics Ltd
Prospect House, Archipelago, Lyon Way
Frimley, Surrey.
GU16 7ER / United Kingdom
Tel: +44 1276 69 34 50
E-mail: salesupport@kyocera.de
www.kyocera.co.uk

Production site and sales office:

KYOCERA Fineceramics Precision GmbH
Lorenz-Hutschenreuther-Strasse 81
95100 Selb / Germany
Tel: +49 9287 807-0
E-mail: info@kyocera-precision.com
www.kyocera-precision.com

Production site and sales office:

KYOCERA Fineceramics Solutions GmbH
Steinzeugstrasse 92
68229 Mannheim / Germany
Tel: +49 621 40547-300
E-mail: info@kyocera-solutions.de
www.kyocera-solutions.de

Sales office Nordics:

KYOCERA Fineceramics Nordics AB
Stormbyvägen 6
163 55 Spånga / Sweden
Tel: +46 8 44 66-910
E-mail: info@kyocera-solutions.se
www.kyocera-solutions.se