



FRIDURIT[®] MODULAR

Laboratory benchtops made of Technical Ceramics
Technical description

www.kyocera-solutions.de

TABLE OF CONTENTS

INTRODUCTION	05
For laboratory perfection	06
FRIDURIT Technical Ceramics	07
Glaze colours	07
FRIDURIT LABORATORY BENCHTOPS	08
Benchtops for wall and island tables	08
Adjustment to structural conditions	09
FRIDURIT LABORATORY SINKS	10
Sinks	10
Cup sinks - oval	11
Cup sinks - round	11
Accessories	13
TECHNOLOGY	14
Cutting signs	14
Edge profiles	15
Apertures and bores	15
Corner solutions	15
MOUNTING INSTRUCTIONS FOR BENCHTOPS	16
Mounting	16
Joint sealing	16
MOUNTING INSTRUCTIONS FOR SINKS	17
Installation options	17
MATERIAL PROPERTIES	18
GENERAL PRODUCT INFORMATION	19



FRIDURIT® MODULAR LABORATORY BENCHTOPS

As a designer, laboratory builder, wholesaler for sanitary products or as a user in a laboratory environment you would like to learn more about laboratory benchtops. This technical description provides you with comprehensive information on FRIDURIT laboratory benchtops made of Technical Ceramics (chemical-technical stoneware). Should you have any questions left unanswered by this description we will be pleased to provide information and support. Details of our products are based on the results of extensive development and the associated test findings in-house and at accredited testing laboratories. Many years of experience in the most varied fields of application provide an additional guarantee for the durability of FRIDURIT laboratory benchtops made of Technical Ceramics. The user, however, remains responsible for verifying our information and recommendations on the basis of his individual requirements and, if necessary, for confirming suitability of the product for his application by means of independent tests.

The statutory warranty provisions apply. We also refer to our General Terms and Conditions of Supply and Payment.

We reserve the right to make technical changes.

KYOCERA Fineceramics Solutions GmbH

Steinzeugstraße 92
68229 Mannheim
Germany
Tel.: +49 (0) 621 - 405 47 400
info@kyocera-solutions.de
www.kyocera-solutions.de

This document is available on the internet as pdf file. Please visit www.kyocera-solutions.de.

September 2019

FRIDURIT[®] MODULAR FOR LABORATORY PERFECTION

Quality demands set by modern laboratories increase side by side with the requirements and standards to which products and services are subjected. This applies to the same degree to the environment in which tests, analyses and experiments are carried out. This is where laboratory work surfaces make a substantial contribution if they can be kept intact, clean and in a hygienic condition. Such laboratory environments support high-quality work processes, or even create in the first place the basic conditions necessary for this. It thus follows that the condition of laboratory work surfaces is decisive for the impression made by the laboratory as a whole.

FRIDURIT full-size laboratory benchtops and sinks made of Technical Ceramics have been used for many years in a wide variety of laboratory applications. FRIDURIT modular laboratory benchtops offer all the advantages of a ceramic work surface at a highly attractive price. They are 20 mm thick and are designed without marine edges. Each benchtop is manufactured to the required dimensions and is supplied ready for mounting. All worktops are self-supporting and require no additional sub-structure so that they can be mounted directly onto the base unit. Four-point support is sufficient.

FRIDURIT laboratory sinks made of Technical Ceramics can be integrated just where access to water is required.

Choose from a wide range of glaze colours and plan your work surface exactly in line with your own requirements.

Our experience in manufacturing ceramic benchtops and sinks is your guarantee for highest quality combined with flexible design.



FRIDURIT[®] TECHNICAL CERAMICS

Thanks to its pore-free surface FRIDURIT Technical Ceramics offers a unique combination of chemical, temperature, scratch and abrasion resistance. With this material profile a perfect working environment can be created and permanently maintained. Even after years of intensive use FRIDURIT laboratory benchtops look just like new.

Technical Ceramics – natural material of a very special kind:

▶ easy to clean

FRIDURIT laboratory benchtops made of Technical Ceramics pose no problems in terms of cleaning. Whether soiled by dyes, varnishes, dirt or grease - they can all be removed without trace. Thanks to their extreme hardness and abrasion resistance our Technical Ceramics products remain totally unaffected, even after undergoing repeated cleaning with aggressive cleaning agents and tools.

▶ resistant to chemicals

FRIDURIT Technical Ceramics products are fully resistant to solvents and chemicals commonly used in the laboratory, e.g. aqua regia, hydrochloric acid, sulphuric acid, nitric acid and sodium hydroxide, even when used at high concentrations and temperatures and with a long reaction time.

▶ microbiologically pure

FRIDURIT laboratory benchtops can be decontaminated and disinfected. Their permanently sealed surfaces preclude breeding grounds for viruses, bacteria or germs.

▶ scratch-proof

FRIDURIT laboratory benchtops always look just like new. Their exceptional scratch resistance prevents any sign of wear.

▶ heat resistant

FRIDURIT Technical Ceramics is resistant to heat from open flames and hot objects, e.g. crucibles. It is non-flammable and completely fire-proof.

▶ environmentally compatible

FRIDURIT Technical Ceramics is manufactured purely and simply from natural earth resources, such as clay, kaolin and feldspar. Such material, which contains no chemical substances, poses no problems in terms of recycling. FRIDURIT Technical Ceramics is thus a classic example of “green” building materials, which represent an important element in implementing “Green Building” concepts. These concepts (e.g. LEED, BREEAM) increase resource efficiency in

buildings while at the same time reducing damaging effects on both health and the environment. Laboratory staff are thus active in a working environment that is free of emissions and thoroughly safe. FRIDURIT Technical Ceramics is nonflammable (Euroclass A1) and does not increase the fire load of buildings.

The FRIDURIT Technical Ceramics manufacturing process takes place in accordance with ISO standards for general process management (ISO 9001:2008), for adherence to environmental aspects (ISO 14001:2004) and for implementing an energy management system (ISO 50001:2011). Sustained development and viability is the maxim for using FRIDURIT Laboratory Technology. This is why we are also a member of EGNATON – The European Association for Sustainable Laboratory Technologies.

GLAZE COLOURS

A wide range of glaze colours (see figure on the right) as well as the option of selecting special colours make FRIDURIT laboratory benchtops and sinks made of Technical Ceramics products that satisfy the very highest aesthetically demands. Laboratory benchtops and sinks are available in plain colour glazing. The benchtops also come in blackspeckled glazing. We will be pleased to send you ceramic colour samples upon request.

(Colours may vary from those illustrated.)

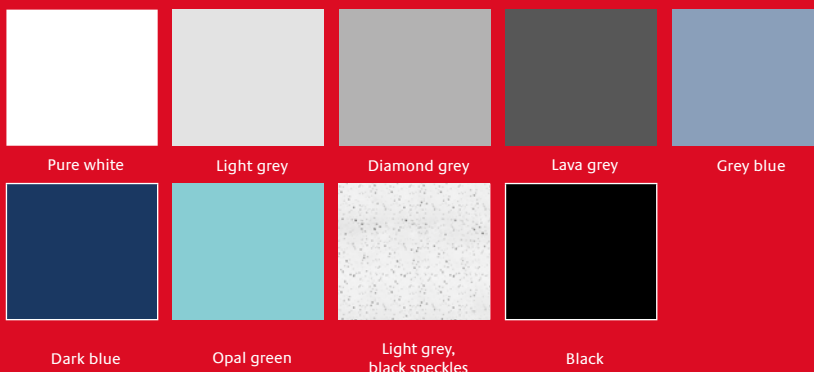

FRIDURIT[®] MODULAR LABORATORY BENCHTOPS



Example of an island bench



Example of a wall bench solution

BENCHTOPS FOR WALL AND ISLAND BENCHES

FRIDURIT modular laboratory benchtops can be combined to wall-fitted laboratory workplaces or to free-standing island bench units. The maximum dimensions of a worktop are 1800 x 900 mm. Within this maximum range individual worktop dimensions can be selected freely. Appropriate adjustments to the substructure result in an attractive joint finish. Benchtop arrangements in combination with other materials can also be implemented according to your individual requirements.

Laboratory sinks can be integrated just where they are needed. They can be top-mounted or flush-mounted.

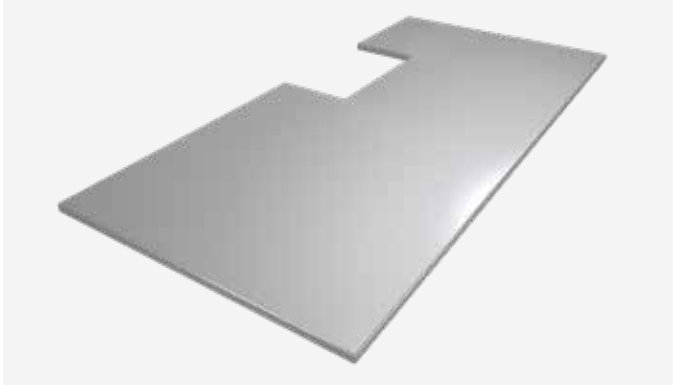

Benchtop with rectangular edge cutout

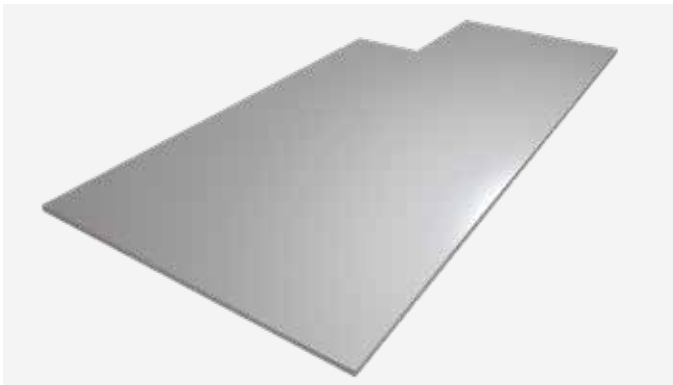

Benchtop with rectangular edge cutout

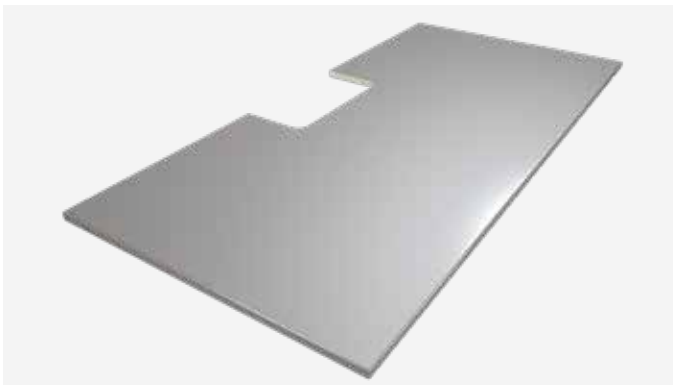

Benchtop with round edge cutout

ADJUSTMENT TO STRUCTURAL CONDITIONS

We will adjust your worktops to the existing structural conditions. Edge cutouts for pipes, struts and supports can be planned in.

FRIDURIT[®] LABORATORY SINKS FOR MOUNTING IN BENCHTOPS

SINKS

FRIDURIT sinks made of Technical Ceramics (chemical-technical stoneware) are the ideal match for FRIDURIT laboratory benchtops. They are glazed on the inside and around the edges and are supplied with a 1½" male screw PP outlet with integrated soil trap and a standpipe.

Options for installation:

- ▶ top-mounted
- ▶ flush-mounted



Internal dimensions (in mm)			External dimensions (in mm)			Weight (in kg)	Order code
l	b	t	L	B	h		
400	400	250	460 ^{±3}	460 ^{±3}	273	20	VBES442
500	400	250	560 ^{±3}	460 ^{±3}	273	25	VBES542
600	400	250	660 ^{±3}	460 ^{±3}	273	27	VBES642

Further sink models are available.

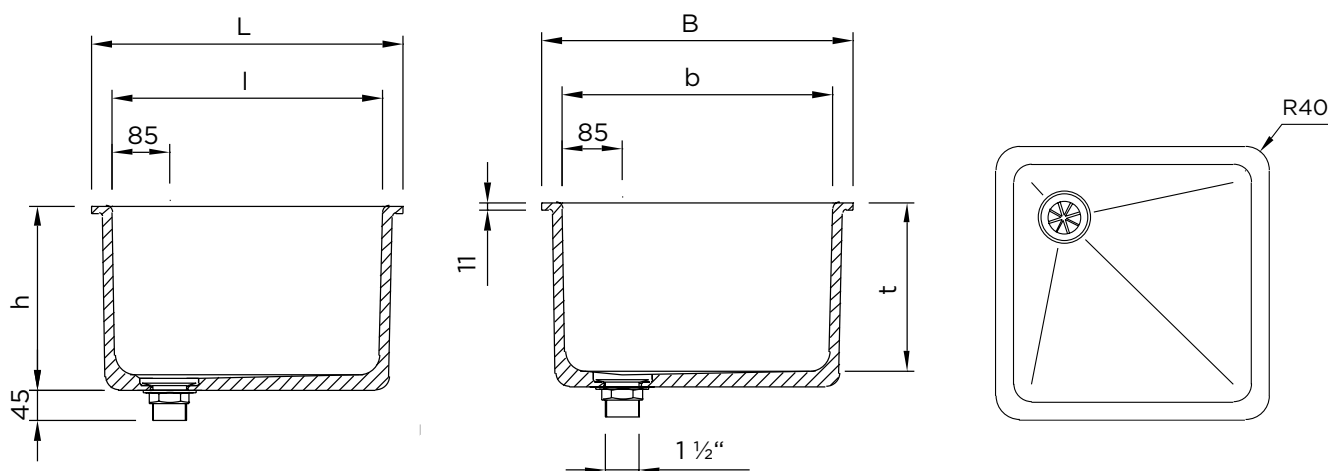

CUP SINKS – OVAL

FRIDURIT cup sinks made of Technical Ceramics (chemicaltechnical stoneware) are the ideal match for FRIDURIT laboratory benchtops. They are glazed on the inside and around the edges and are supplied with a 1½" male screw PP outlet with integrated soil trap.



Options for installation:

- ▶ top-mounted
- ▶ flush-mounted

Internal dimensions (in mm)			External dimensions (in mm)			Weight (in kg)	Order code
l	b	t	L	B	h		
250	95	112	294 ^{±3}	140 ^{±3}	133	2.4	VBPE291

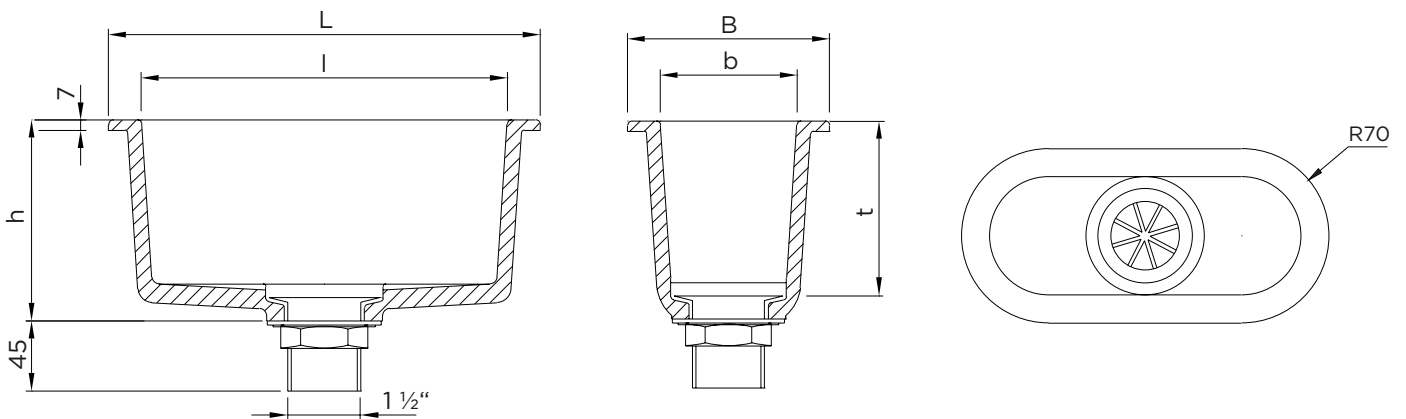

CUP SINKS – ROUND

FRIDURIT cup sinks made of Technical Ceramics (chemicaltechnical stoneware) are the ideal match for FRIDURIT laboratory benchtops. They are glazed on the inside and around the edges and are supplied with a 1½" male screw PP outlet with integrated soil trap.

Options for installation:

- ▶ top-mounted
- ▶ flush-mounted



Internal dimensions (in mm)		External dimensions (in mm)		Weight (in kg)	Order code
Øb	t	B	h		
105	112	145 ^{±3}	137	1.5	VBPE111

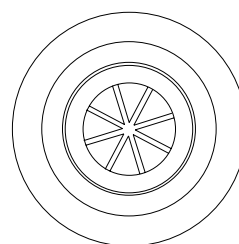
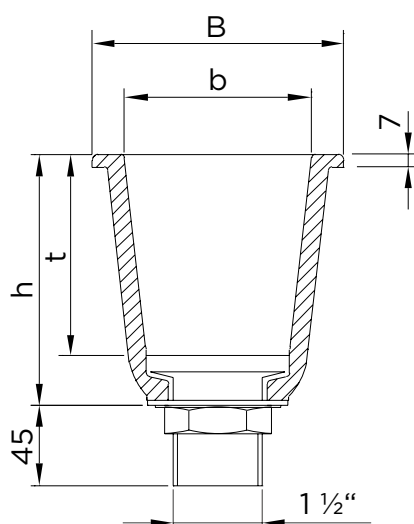

FRIDURIT[®] LABORATORY SINKS ACCESSORIES

P-TRAP

A polypropylene waste trap (stench trap) is available for connection to the waste-water pipe.



Description	Order code
Polypropylene waste trap, horizontal/vertical Outlet: compression fitting DN50 Connection: 1 1/2" female screw x 100	BZS001

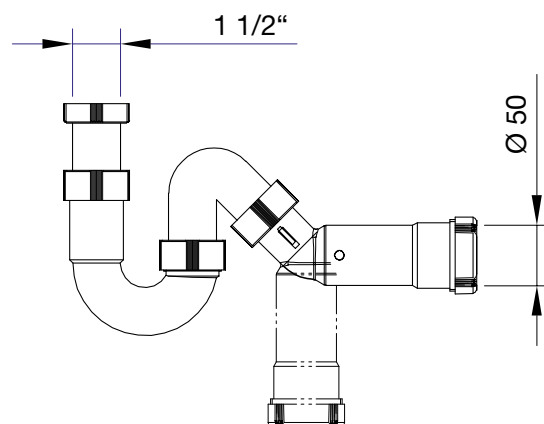

FRIDURIT[®] MODULAR TECHNOLOGY

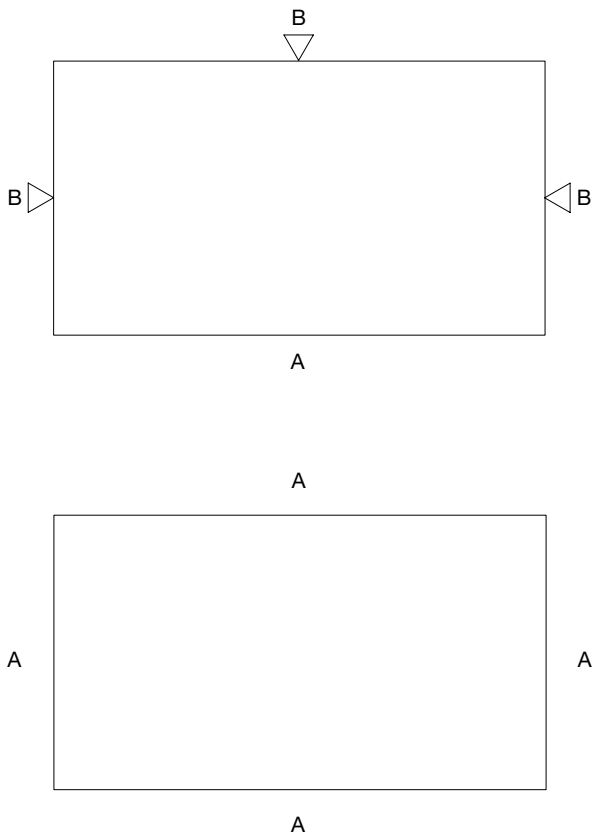

CUTTING SIGNS

Depending on the mounting environment FRIDURIT modular benchtops are manufactured with cut (i.e. unglazed) or glazed edges. We recommend a cut edge if it is “not visible”, e.g. when wall-fitted or service spine fitted. Joint edges are always cut. This leads to lower tolerances and ensures a smoother joint.

The edge finish is marked with the following symbols:

- ▼ = cut, unglazed edge (mandatory information)
- = glazed edge (optional information)

During the manufacturing process ceramic benchtops are subject to material-specific shrinkage. Even when using the most advanced manufacturing technologies this cannot always be avoided. The shrinkage range varies from ± 1 mm to $\pm 1\%$, depending on edge finishing.

The figures on the left show examples of benchtops with glazed and/or cut edges. For better understanding, the edge profiles have been marked with the respective letters (see Chapter on “Edge Profiles”). Indicating the edge profile by means of the symbols for the edge finish is sufficient when ordering.

○ A
▽ B

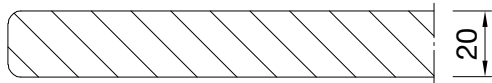

EDGE PROFILES

FRIDURIT modular laboratory benchtops made of Technical Ceramic can be manufactured with glazed edges (edge profile „A“) or with cut edges (edge profile „B“).

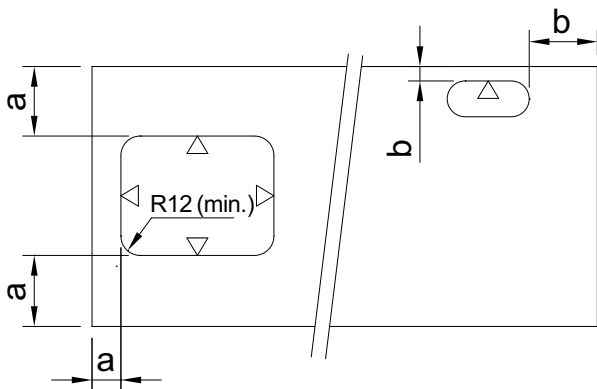

APERTURES AND BORES

The location of apertures and bores on the worktop can be selected freely while taking account of the minimum distances required by the material. Apertures are always unglazed.

The following principles apply to the required minimum distance to glazed or cut edges:

MINIMUM DISTANCES FOR SINK APERTURES:

a: min. 100 mm

MINIMUM DISTANCES FOR CUP SINK APERTURES:

b: min. 50 mm

Bores are always unglazed and are available in the following standard diameters:

Ø 5 / 8 / 10 / 15 / 20 / 25 / 28 / 30 / 35 / 40 / 50 mm

Other diameters available upon request.

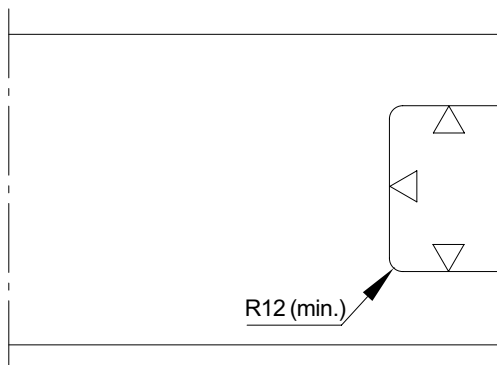

EDGE CUTOUTS

The following applies for edge cutouts:

\ Edge cutouts are always unglazed

\ Minimum corner radius: 12 mm

LABORATORY BENCHTOPS MOUNTING INSTRUCTIONS



Mounting benchtops with four-point support on levelling devices

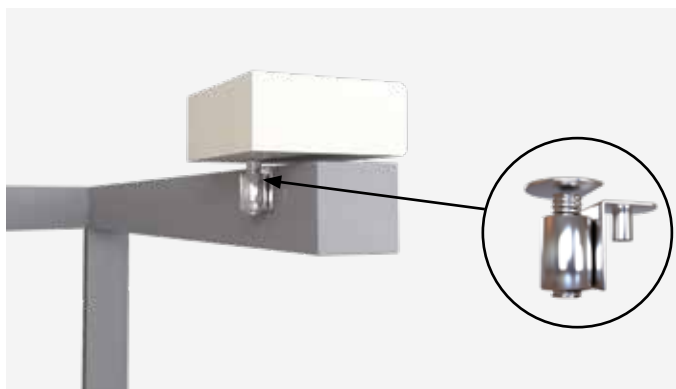

Levelling details

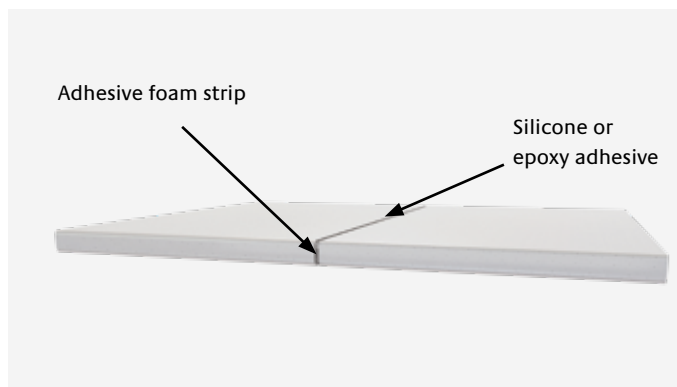

Joint details

MOUNTING

FRIDURIT laboratory benchtops are provided ready for mounting.

Due to their extreme stability, FRIDURIT laboratory benchtops are self-supporting. This means that four-point support is sufficient (see illustration).

The breaking load (P) of the benchtop without cutouts depends on the width (B) and length (L) of the worktop:

$$P \text{ (in kg)} = 1000 \times B/L \text{ (in mm)}.$$

For swift and easy installation we recommend mounting benchtops on levelling devices (order code PZN31).

JOINT SEALING

There are two ways of sealing full-size FRIDURIT laboratory benchtops:

\ permanently elastic, using silicone

\ hardening, e.g. using epoxy sealing material

We generally recommend the use of adhesive foam strip or similar materials as spacers in order to ensure an even joint. Joint width should already be taken into consideration when planning benchtop dimensions.

We will be pleased to send you further instructions containing further details.

LABORATORY SINKS MOUNTING INSTRUCTIONS



Example of top-mounted sink

TOP-MOUNTED

Sinks are top-mounted in a cut aperture (unglazed) of the full-size FRIDURIT laboratory benchtop and then sealed with silicon. Uncontrolled leakage of liquid into the waste-water system can thus be prevented.

A top-mounted installation is only possible with the built-in versions, order code VBES or VBPE.



Example flush-mounted sink

FLUSH-MOUNTED

Sinks are flush-mounted in the stepped aperture (unglazed) of the full-size FRIDURIT laboratory benchtop and sealed with permanently elastic silicone or by means of hardening.

A flush-mounted installation is only possible with the built-in versions, order code VBES or VBPE.

Please always observe the material-related recommendations of the worktop manufacturer prior to fitting FRIDURIT laboratory sinks.

FRIDURIT[®] TECHNICAL CERAMICS

MATERIAL PROPERTIES

PHYSICAL PROPERTIES

Property	Result	Unit	Standard applied
Raw density	2.24	g/cm ³	DIN EN ISO 10545-3
Weight	46	kg/m ²	
Scratch hardness	6	Mohs scale	DIN EN 15771
Crazing resistance	no crazing		DIN EN ISO 10545-11
Wear	Class 4		DIN EN ISO 10545-7

MECHANICAL PROPERTIES

Property	Result	Unit	Standard applied
Cold compression strength	159	MPa	DIN EN 993-5
Bending strength	42.1	N/mm ²	DIN EN ISO 10545-4
Static modulus of elasticity	39	GPa	DIN EN 993-6

THERMAL PROPERTIES

Property	Result	Unit	Standard applied
Fire load	non-flammable, Euroclass A1		DIN EN 13501-1
Thermal conductivity	1.57	W/mK	DIN EN 821-2
Thermal expansion	(α_{25-400}) $5.6 \cdot 10^{-6}$ (α_{25-800}) $5.9 \cdot 10^{-6}$	K ⁻¹	DIN 51045-2
Application temperature	up to 550 °C, temporary exposure up to 800 °C		

CHEMICAL RESISTANCE

Property	Result	Description	Standard applied
Resistance to testing solutions (e.g. solution of hydrochloric acid and sodium hypochloride)	No visible effect on the test specimens.	Test samples made of FRIDURIT Technical Ceramics are exposed to testing solutions. The samples are examined visually after a specific period of time.	DIN EN ISO 10545-13
Resistance to staining (e.g. chrome green)	Stains can be completely removed with hot water (Class 5).		DIN EN ISO 10545-14

OPTICAL PROPERTIES

Silk finish surface in the current glaze colours. Other colours are available to special order. Colour samples are available on request.

QUALITY GUIDELINES

Before leaving our factory all our products are subjected to stringent controls in order to ensure the same high standards of quality. Just like wood or leather products, which are much appreciated for their individual grain and texture, FRIDURIT laboratory benchtops made of Technical Ceramics may show optical irregularities. Natural variations in colour and appearance on the same product and between the various benchtops are typical for the material and are unavoidable due to the complex manufacturing process. In addition, dimensional tolerances as a result of material properties may arise (see DIN 12916).

The features indicated do not affect quality and thus do not constitute any defects. Far more, they belong to the characteristic properties of the material.

CLEANING

The high density of the material results in easy-to-clean, permanently sealed surfaces. We recommend cleaning the FRIDURIT benchtops with a sponge or cloth using traditional cleaning agents such as those used in bathrooms. Stubborn dirt can be removed using an abrasive sponge suitable for glass ceramics.

We will be pleased to answer any questions you may have.



KYOCERA Fin ceramics Solutions GmbH

Steinzeugstraße 92
68229 Mannheim / Germany
Tel.: +49 (0) 621 - 405 47 400
E-Mail: info@kyocera-solutions.de
www.kyocera-solutions.de

European Headquarters:

KYOCERA Europe GmbH

Fritz-Mueller-Strasse 27
73730 Esslingen / Germany
Tel.: +49 (0)711 - 93 93 4-0
E-Mail: info.fc@kyocera.de
www.kyocera.eu