



## **FRIDURIT<sup>®</sup> PREMIUM**

Laboratory benchtops  
made of Technical Ceramics

Technical description

[www.kyocera-solutions.de](http://www.kyocera-solutions.de)



# TABLE OF CONTENTS

<b>INTRODUCTION</b>	<b>05</b>
For laboratory perfection	06
FRIDURIT Technical Ceramics	07
Glaze colours	07
<b>LABORATORY BENCHTOPS</b>	<b>08</b>
Benchtops for wall and island tables	08
Benchtops for fume cupboards	09
Marine edge	10
Design examples	11
Adjustment to structural conditions	12
<b>LABORATORY SINKS</b>	<b>14</b>
Sinks	14
Cup sinks - oval	15
Cup sinks - round	16
Accessories	17
<b>TECHNOLOGY</b>	<b>18</b>
Cutting signs	18
Edge profiles	19
Apertures and bores	20
Drainage grooves	21
Corner solutions	21
<b>MOUNTING INSTRUCTIONS FOR BENCHTOPS</b>	<b>22</b>
Mounting	24
Joint sealing	24
<b>MOUNTING INSTRUCTIONS FOR SINKS</b>	<b>25</b>
Installation options	25
<b>MATERIAL PROPERTIES</b>	<b>26</b>
<b>GENERAL PRODUCT INFORMATION</b>	<b>27</b>



# FRIDURIT® PREMIUM LABORATORY BENCHTOPS

As a designer, laboratory builder, wholesaler for sanitary products or as a user in a laboratory environment you would like to learn more about laboratory benchtops. This technical description provides you with comprehensive information on FRIDURIT laboratory benchtops made of Technical Ceramics (chemical-technical stoneware). Should you have any questions left unanswered by this description we will be pleased to provide information and support. Details of our products are based on the results of extensive development and the associated test findings in-house and at accredited testing laboratories. Many years of experience in the most varied fields of application provide an additional guarantee for the durability of FRIDURIT laboratory benchtops made of Technical Ceramics. The user, however, remains responsible for verifying our information and recommendations on the basis of his individual requirements and, if necessary, for confirming suitability of the product for his application by means of independent tests.

Our technical specifications are based on DIN 12915 and DIN 12916.

The statutory warranty provisions apply.  
We also refer to our General Terms and Conditions of Supply and Payment.

## **KYOCERA Fineceramics Solutions GmbH**

Steinzeugstraße 92  
68229 Mannheim  
Germany  
Phone: +49 (0) 621 - 405 47 400  
info@kyocera-solutions.de

This document is available on the internet as pdf file. Please visit [www.kyocera-solutions.de](http://www.kyocera-solutions.de).

**January 2020**

**We reserve the right to make technical changes.**

# FOR LABORATORY PERFECTION

Quality demands set by modern laboratories increase side by side with the requirements and standards to which products and services are subjected. This applies to the same degree to the environment in which tests, analyses and experiments are carried out. This is where laboratory work surfaces make a substantial contribution if they can be kept intact, clean and in a hygienic condition. Such laboratory environments support high-quality work processes, or even create in the first place the basic conditions necessary for this. It thus follows that the condition of laboratory work surfaces is decisive for the impression made by the laboratory as a whole.

FRIDURIT full-size laboratory benchtops and sinks made of Technical Ceramics have been used for many years in a wide variety of laboratory applications. With its porefree surface FRIDURIT Technical Ceramics offers a unique combination of chemical resistance, scratch resistance and thermal stability. This property profile makes it possible to maintain permanently the perfect working environment. Even after many years of intensive use FRIDURIT laboratory benchtops still look just like new.

Each FRIDURIT premium laboratory benchtop made of Technical Ceramics is manufactured individually and is supplied ready for mounting. An integrated ceramic marine edge provides protection from liquid overspill. All worktops are self-supporting and require no additional sub-structure so that they can be mounted directly onto the base unit. Four-point support is sufficient.

FRIDURIT laboratory sinks made of Technical Ceramics can be integrated just where access to water is required. Choose from a wide range of glaze colours and plan your work surface exactly in line with your own requirements.

Our experience in manufacturing ceramic benchtops and sinks is your guarantee for highest quality combined with flexible design.



# FRIDURIT® TECHNICAL CERAMICS

**Technical Ceramics** – natural material of a very special kind:

▶ **easy to clean**

FRIDURIT laboratory benchtops made of Technical Ceramics pose no problems in terms of cleaning. Whether soiled by dyes, varnishes, dirt or grease - they can all be removed without trace. Thanks to their extreme hardness and abrasion resistance our Technical Ceramics products remain totally unaffected, even after undergoing repeated cleaning with aggressive cleaning agents and tools.

▶ **resistant to chemicals**

FRIDURIT Technical Ceramics products are fully resistant to solvents and chemicals commonly used in the laboratory, e.g. aqua regia, hydrochloric acid, sulphuric acid, nitric acid and sodium hydroxide, even when used at high concentrations and temperatures and with a long reaction time.

▶ **microbiologically pure**

FRIDURIT laboratory benchtops can be decontaminated and disinfected. Their permanently sealed surfaces preclude breeding grounds for viruses, bacteria or germs

▶ **scratch-proof**

FRIDURIT laboratory benchtops always look just like new. Their exceptional scratch resistance prevents any sign of wear.

▶ **heat resistant**

FRIDURIT Technical Ceramics is resistant to heat from open flames and hot objects, e.g. crucibles. It is non-flammable and completely fire-proof.

▶ **environmentally compatible**

FRIDURIT Technical Ceramics is manufactured purely and simply from natural earth resources, such as clay, kaolin and feldspar. Such material, which contains no chemical substances, poses no problems in terms of recycling. FRIDURIT Technical Ceramics is thus a classic example of “green” building materials, which represent an important element in implementing “Green Building” concepts. These concepts (e.g. LEED, BREEAM) increase resource efficiency in buildings while at the same time reducing damaging effects on both health and the environment. Laboratory staff are thus active in a working environment that is free of emissions and thoroughly safe. FRIDURIT Technical Ceramics is nonflammable (Euroclass A1) and does not increase the fire load of buildings.

The FRIDURIT Technical Ceramics manufacturing process takes place in accordance with ISO standards for general process management (ISO 9001:2008), for adherence to environmental aspects (ISO 14001:2004) and for implementing an energy management system (ISO 50001:2011). Sustained development and viability is the maxim for using FRIDURIT Laboratory Technology. This is why we are also a member of EGNATON – The European Association for Sustainable Laboratory Technologies.

## GLAZE COLOURS

A wide range of glaze colours (see figure on the right) as well as the option of selecting special colours make FRIDURIT laboratory benchtops and sinks made of Technical Ceramics products that satisfy the very highest aesthetically demands. Laboratory benchtops and sinks are available in plain colour glazing. The benchtops also come in blackspeckled glazing. We will be pleased to send you ceramic colour samples upon request.

(Colours may vary from those illustrated.)

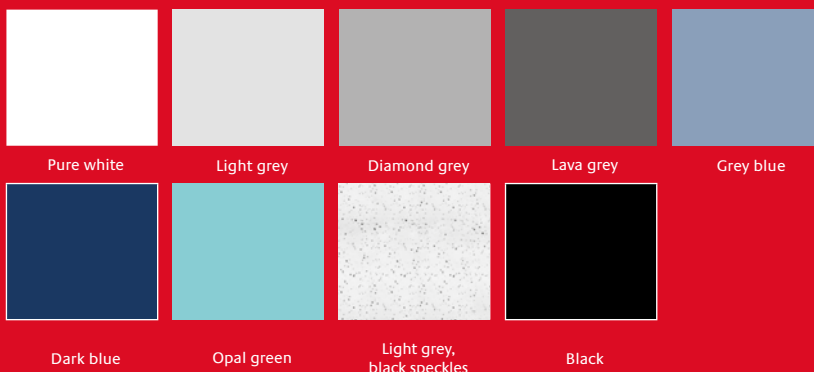

# FRIDURIT® PREMIUM LABORATORY BENCHTOPS



Example of an island bench with head-end sink unit<sup>1</sup>



Example of a wall bench solution

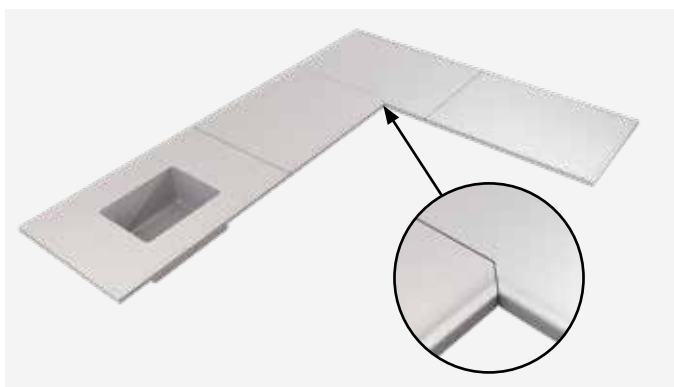

Example of a wall bench corner solution

## BENCHTOPS FOR WALL AND ISLAND BENCHES

FRIDURIT premium laboratory benchtops can be combined to wall-fitted laboratory workplaces or to free-standing island bench units. The maximum dimensions of a worktop are 900 x 2000 mm. Within this maximum range individual worktop dimensions can be selected freely. Appropriate adjustments to the substructure fittings result in an attractive joint finish. The circumferential marine edge means that a closed benchtop arrangement of any length is possible. Benchtop arrangements in combination with other materials can also be implemented according to your individual requirements.

Laboratory sinks can be integrated just where they are needed. They can be top-mounted, flush-mounted or underfixed.

The joint-free marine edge formed onto the benchtop prevents any liquid overspill from the sink area to the adjacent working area.

<sup>1</sup>Splash guard not included





Example of edge cutouts for fume cupboard side posts



Example of a lateral raised edge with cup sink



Example of a spillover weir

### **BENCHTOPS FOR FUME CUPBOARDS**

Due to their exceptional degree of chemical, thermal and mechanical durability FRIDURIT premium laboratory benchtops provide the ideal work surface, especially in the fume cupboard area.

The joint-free, 7 mm high marine edge provides full protection from liquid overspill. In addition, an aerodynamically formed front edge can positively influence air conduction in the fume cupboard.

The geometry of the worktop can be perfectly adjusted to fume cupboard dimensions. Worktop cutouts can be made with elevated marine edge.

If so required, cup sinks can be integrated in the fume cupboard plate. Accidental release of liquids into the wastewater system can be prevented in various ways:

- ▶ by means of a broad raised edge, placed either laterally or at the back. The raised edge can at the same time be used as tap landing. In such case, the cup sink is mounted onto the fume cupboard plate from below.
- ▶ by means of a spillover weir. Here, the cup sink is also fixed to the fume cupboard plate from below.
- ▶ by means of a cup sink mounted into the fume cupboard plate from above.

# FRIDURIT® PREMIUM LABORATORY BENCHTOPS

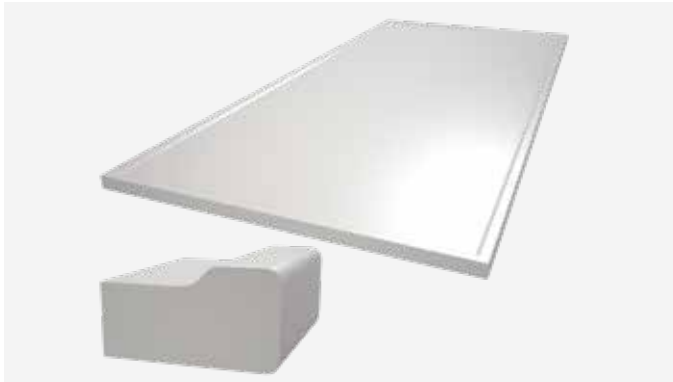

Front marine edge type „C“

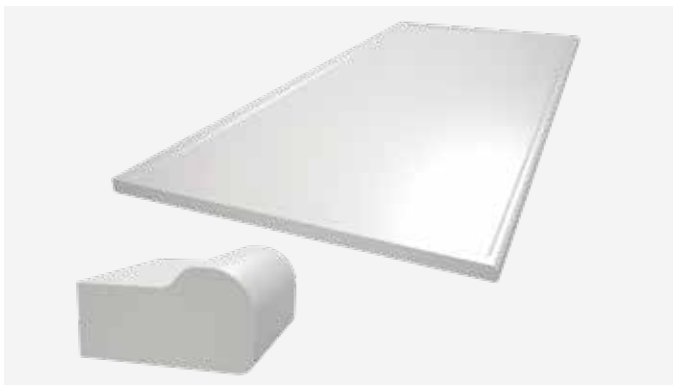

Front marine edge type „P“

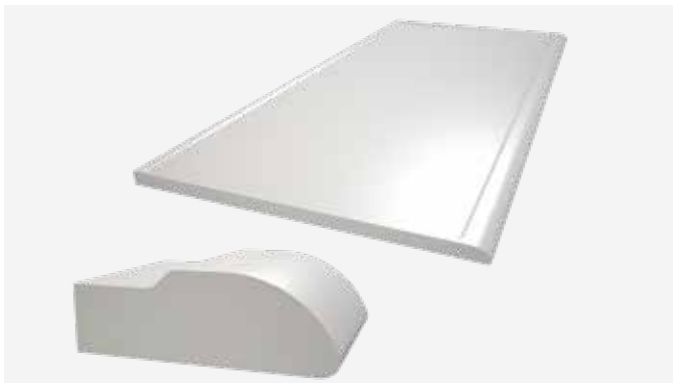

Front marine edge type „Q“

## MARINE EDGE

In numerous laboratory workplaces it is appropriate or in many cases even mandatory to ensure protection from liquid overspill.

FRIDURIT premium laboratory benchtops are manufactured with integrated marine edge. The marine edge and work surface thus form a joint-free unit. Optimum cleaning without any risk of damaging the work surface is thus possible at all times.

Particularly in the fume cupboard area the shape of the benchtop front edge can positively influence air conduction.

Here, an elongated, rounded profile (edge type “Q”) is often used.

Please see Page 19 for an overview of edge profiles.

We can of course also manufacture FRIDURIT laboratory benchtops as benchtops with just one marine edge at the front or without marine edge.



Sink unit with circumferential marine edge and drainage grooves



Sink unit with circumferential marine edge



Split sink unit with tap landing

### DESIGN EXAMPLES

Each FRIDURIT premium laboratory benchtop made of Technical Ceramics is manufactured individually. This enables you to arrange your work surface exactly according to your requirements, taking into account the material properties of Technical Ceramics. Some examples can be seen on the right.

Our Technical Service Team will be pleased to answer any questions you may have.

---

FRIDURIT premium laboratory benchtops made of Technical Ceramics give you the flexibility to create your ideal working environment.

---

# FRIDURIT® PREMIUM LABORATORY BENCHTOPS



Worktop with circumferential marine edge and edge cutout



Worktop with edge cutout



Worktop with round edge cutout

## ADJUSTMENT TO STRUCTURAL CONDITIONS

We will adjust your worktops to the existing structural conditions. Edge cutouts for pipes, struts and supports can be planned in. Here you can also choose between open worktops and closed worktops with circumferential marine edge.



### Tailor-made perfection for every wish

The experience of many years means we are able to manufacture individual solutions down to the finest detail. Whether you are looking for a permanently resilient work surface or your main concern is environmental protection and, naturally, if you have special wishes regarding the size, shape and colour of your worktops and laboratory sinks - we guarantee you both top quality and a unique design.

# FRIDURIT® LABORATORY SINKS FOR MOUNTING IN BENCHTOPS

## SINKS

FRIDURIT sinks made of Technical Ceramics (chemical-technical stoneware) are the ideal match for FRIDURIT laboratory benchtops. They are glazed on the inside and around the edges and are supplied with a 1½" male screw PP outlet with integrated soil trap and a standpipe.

### Options for installation:

- ▶ top-mounted
- ▶ flush-mounted
- ▶ under-fixed



Internal dimensions (in mm)			External dimensions (in mm)			Weight (in kg)	Order code
l	b	t	L	B	h		
400	400	250	460 <sup>±3</sup>	460 <sup>±3</sup>	273	20	VBES442
500	400	250	560 <sup>±3</sup>	460 <sup>±3</sup>	273	25	VBES542
600	400	250	660 <sup>±3</sup>	460 <sup>±3</sup>	273	27	VBES642

Further sink models are available.

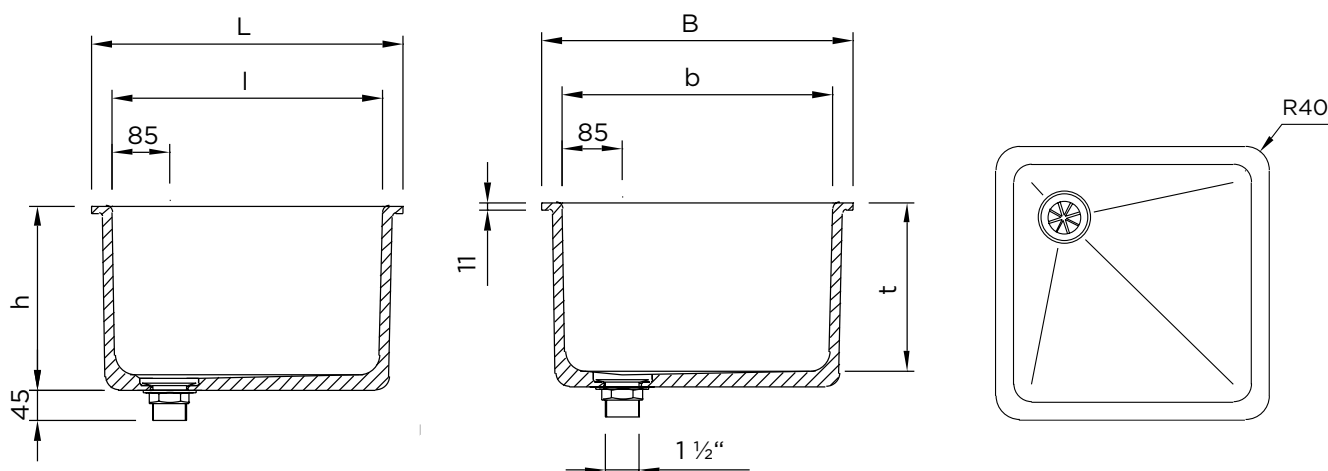

### CUP SINKS – OVAL

FRIDURIT cup sinks made of Technical Ceramics (chemicaltechnical stoneware) are the ideal match for FRIDURIT laboratory benchtops. They are glazed on the inside and around the edges and are supplied with a 1½" male screw PP outlet with integrated soil trap.

#### Options for installation:

- ▶ top-mounted
- ▶ flush-mounted
- ▶ under-fixed



Internal dimensions (in mm)			External dimensions (in mm)			Weight (in kg)	Order code
l	b	t	L	B	h		
250	95	112	294 <sup>±3</sup>	140 <sup>±3</sup>	133	2.4	VBPE291

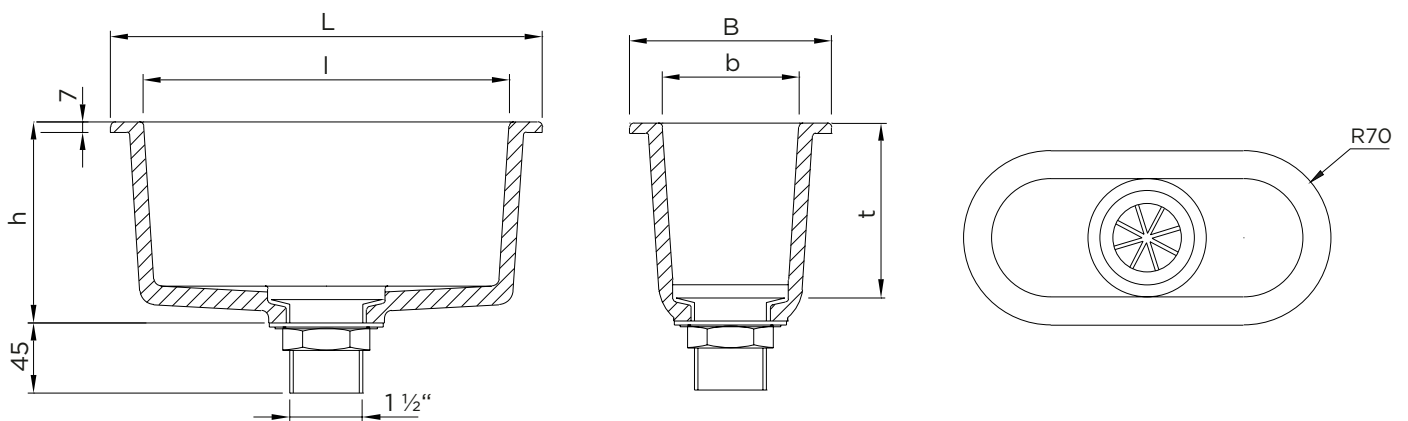

### CUP SINKS – ROUND

FRIDURIT cup sinks made of Technical Ceramics (chemicaltechnical stoneware) are the ideal match for FRIDURIT laboratory benchtops. They are glazed on the inside and around the edges and are supplied with a 1½" male screw PP outlet with integrated soil trap.

#### Options for installation

- ▶ top-mounted
- ▶ flush-mounted
- ▶ under-fixed



Internal dimensions (in mm)		External dimensions (in mm)		Weight (in kg)	Order code
Øb	t	B	h		
105	112	145 <sup>±3</sup>	137	1.5	VBPE111

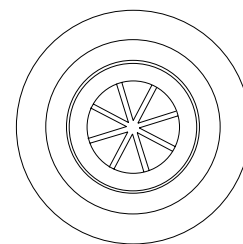
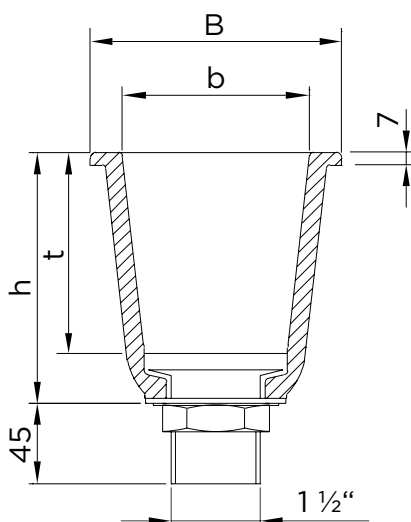



# FRIDURIT® LABORATORY SINKS ACCESSORIES

## P-TRAP

A polypropylene waste trap (stench trap) is available for connection to the waste-water pipe.



Description	Order code
Polypropylene waste trap, horizontal/vertical Outlet: compression fitting DN50 Connection: 1 1/2" female screw x 100	BZS001

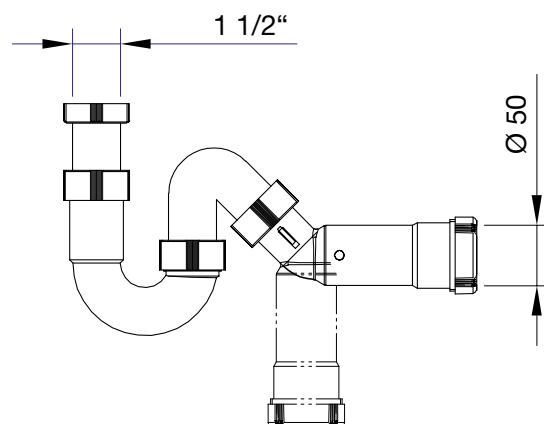

# FRIDURIT® PREMIUM TECHNOLOGY

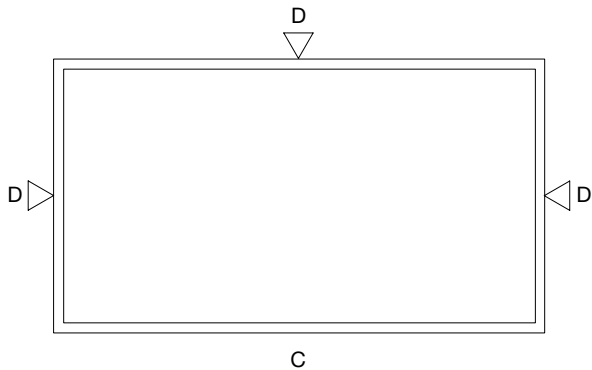

C

C

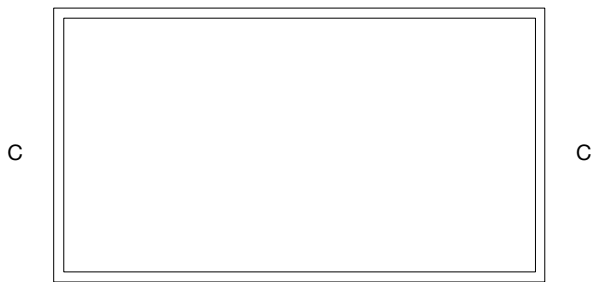

C

C

C

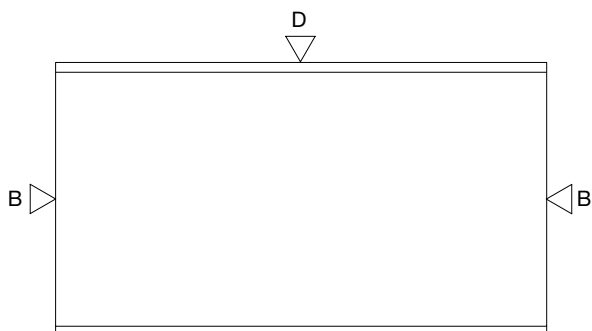

B

B

C

## CUTTING SIGNS

Depending on the mounting environment FRIDURIT premium benchtops are manufactured with cut (i.e. unglazed) or glazed edges. We recommend a cut edge if it is "not visible", e.g. when wall-fitted or service spine fitted. Joint edges are always cut. This leads to lower tolerances and ensures a smoother joint.

The edge finish is marked with the following symbols:

▽ = cut, unglazed edge (mandatory information)

○ = glazed edge (optional information)

During the manufacturing process ceramic benchtops are subject to material-specific shrinkage. Even when using the most advanced manufacturing technologies this cannot always be avoided. The shrinkage range varies from  $\pm 1$  mm to  $\pm 1\%$ , depending on edge finishing.

The figures on the left show examples of benchtops with glazed and/or cut edges. For better understanding, the edge profiles have been marked with the respective letters (see Chapter on "Edge Profiles"). Indicating the edge profile by means of the symbols for the edge finish is sufficient when ordering.

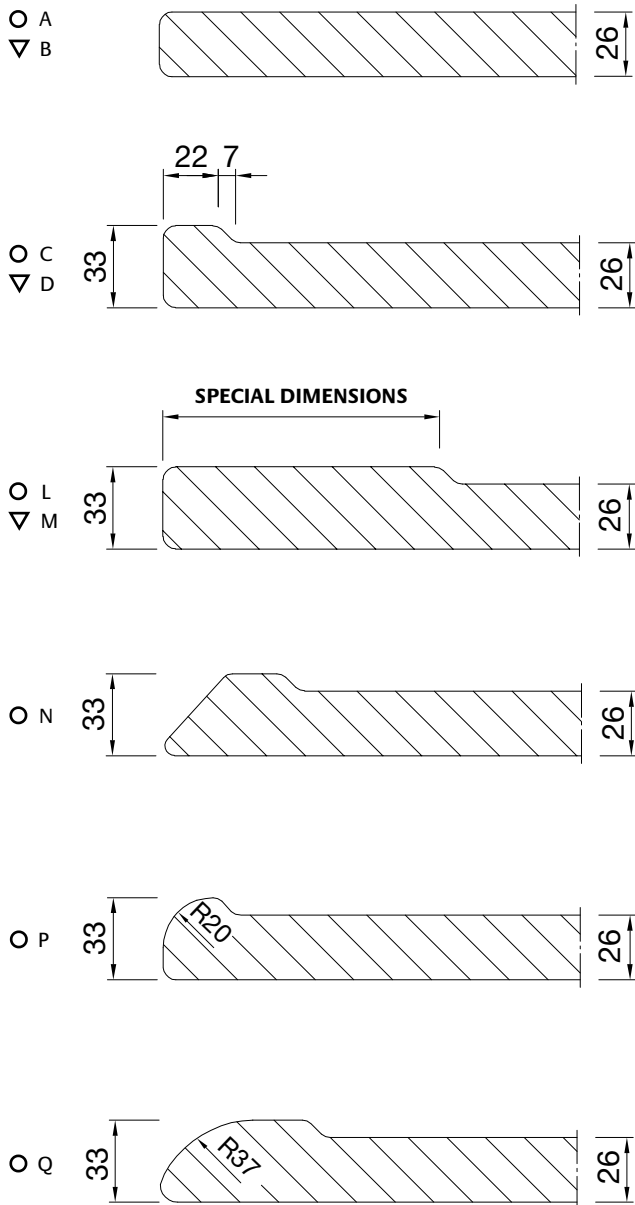

## EDGE PROFILES

FRIDURIT premium laboratory benchtops made of Technical Ceramics can be manufactured with a wide variety of edge profiles.

### Standard edge profiles

Edge profiles „A“ and „B“ (without marine edge) as well as „C“ and „D“ (with marine edge) are the standard edge profiles for premium laboratory benchtops.

The following applies to the technical illustrations:

- ▶ A double line symbolises a marine edge manufactured as standard in profile „C“ (glazed) or „D“ (cut/unglazed).
- ▶ A single line depicts edge profile „A“ or „B“.

### Other edge profiles

Apart from the standard profiles „C“ and „D“ the marine edge can be manufactured in further geometric shapes. Edge profiles „N“, „O“ and „Q“ are the preferred profiles for the front edges of the fume cupboard plate in order to positively influence air conduction.

---

A joint-free marine edge ensures the highest levels of safety and hygiene.

---

# FRIDURIT® PREMIUM TECHNOLOGY

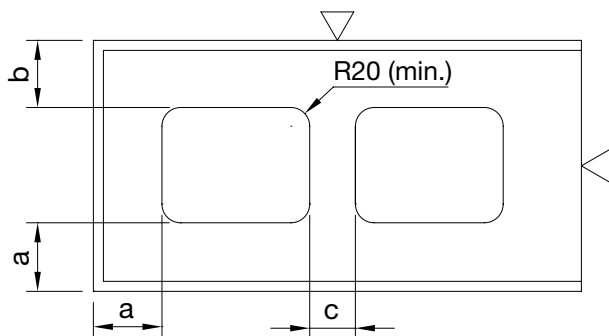

## APERTURES AND BORES

The location of apertures and bores on the worktop can be selected freely while taking account of the minimum distances required by the material. The following basic principles apply:

### Minimum distances for glazed apertures:

- a: min. 135 mm  
(glazed aperture - glazed edge)
- b: min. 70 mm  
(glazed aperture - cut edge)
- c: min. 100 mm  
(glazed aperture - glazed aperture)

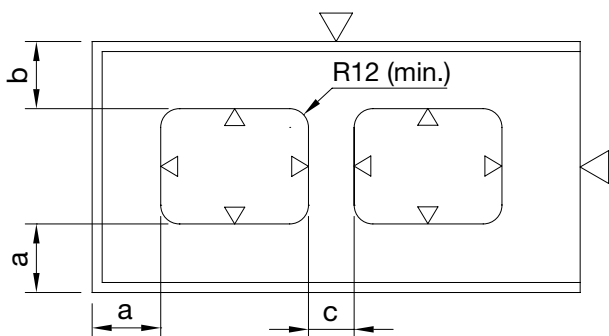

### Minimum distances for unglazed apertures:

- a: min. 50 mm  
(cut aperture - glazed edge)
- b: min. 50 mm  
(cut aperture - cut edge)
- c: min. 100 mm  
(cut aperture - cut aperture)

Bores are always unglazed and are available in the following standard diameters:

Ø 5 / 8 / 10 / 15 / 20 / 25 / 28 / 30 / 35 / 40 / 50 mm

Other dimensions on request.

## EDGE CUTOUTS

The following applies to edge cutouts:

- ▶ Minimum corner radius for glazed edge cutouts: 20 mm
- ▶ Minimum corner radius for unglazed edge cutouts: 12 mm

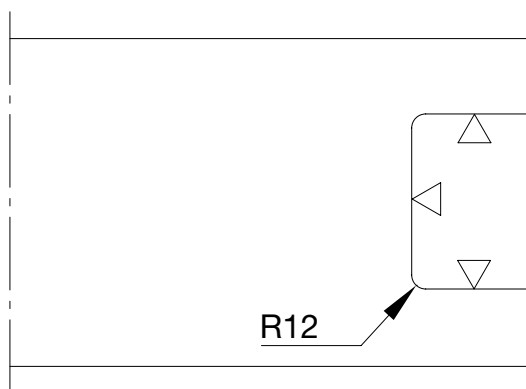

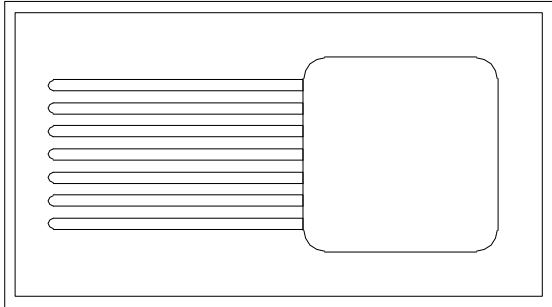

### **DRAINAGE GROOVES**

Drainage grooves with a maximum length of 500 mm can be integrated in the sink unit. Drainage grooves can only be supplied in combination with a glazed aperture and underfixed sink.

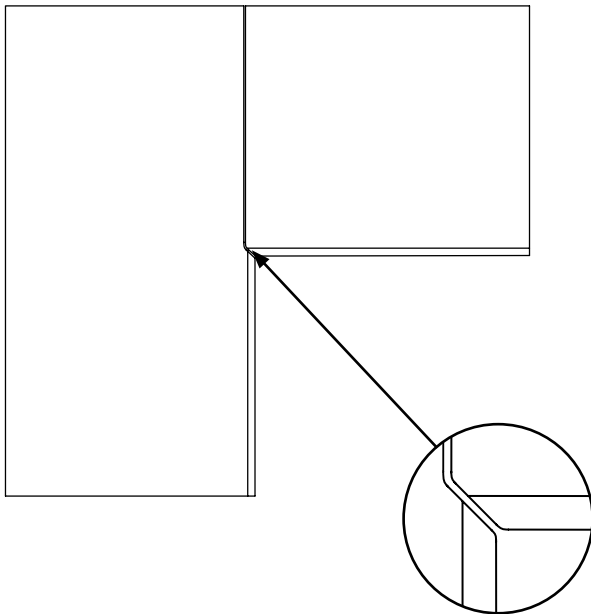

### **CORNER SOLUTIONS**

For corner solutions the mitre cuts illustrated here are provided upon request.

---

Each FRIDURIT premium laboratory benchtop is manufactured individually according to your requirements and is supplied ready for mounting.

---





MOUNTING INSTRUCTIONS  
**LABORATORY BENCHTOPS  
AND SINKS**

# LABORATORY BENCHTOPS MOUNTING INSTRUCTIONS



Mounting benchtops with four-point support on levelling devices

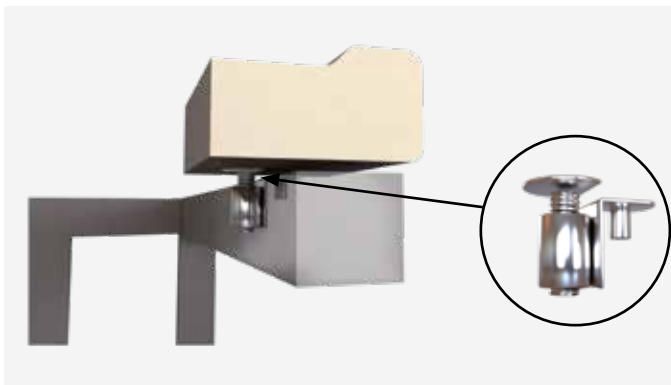

Levelling details

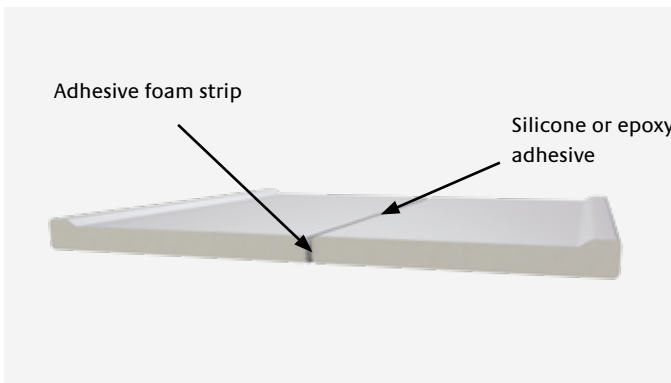

Joint details

## **MOUNTING**

FRIDURIT laboratory benchtops are provided ready for mounting.

Due to their extreme stability, FRIDURIT laboratory benchtops are self-supporting. This means that four-point support is sufficient (see illustration).

The breaking load (P) of the benchtop without cutouts depends on the width (B) and length (L) of the worktop:

$$P \text{ (in kg)} = 1600 \times B/L \text{ (in mm)}$$

For swift and easy installation we recommend mounting benchtops on levelling devices (Order code PZN31).

## **JOINT SEALING**

There are two ways of sealing full-size FRIDURIT laboratory benchtops:

- ▶ permanently elastic, using silicone
- ▶ hardening, e.g. using epoxy sealing material

We generally recommend the use of adhesive foam strip or similar materials as spacers in order to ensure an even joint. Joint width should already be taken into consideration when planning benchtop dimensions.

We will be pleased to send you further instructions containing further details.



# LABORATORY SINKS MOUNTING INSTRUCTIONS



Example of top-mounted sink

## TOP-MOUNTED

Sinks are top-mounted in a cut aperture (unglazed) of the full-size FRIDURIT laboratory benchtop and then sealed with silicon. Uncontrolled leakage of liquid into the waste-water system can thus be prevented.

A top-mounted installation is only possible with the built-in versions, order code VBES or VBPE.



Example flush-mounted sink

## FLUSH-MOUNTED

Sinks are flush-mounted in the stepped aperture (unglazed) of the full-size FRIDURIT laboratory benchtop and sealed with permanently elastic silicone or by means of hardening.

A flush-mounted installation is only possible with the built-in versions, order code VBES or VBPE.



Example under-fixed sink

## UNDER-FIXED

Sinks can be joined to the full-size FRIDURIT laboratory benchtops by means of hardening. No additional sink-support structures are in this case needed.

Alternatively, the sinks can also be sealed using permanently elastic silicone. In this case, a support structure must be provided by the customer. Permanently elastic sealing allows later dismantling of the sink.

---

Please always observe the material-related recommendations of the worktop manufacturer prior to fitting FRIDURIT laboratory sinks.

---

# FRIDURIT® TECHNICAL CERAMICS

## MATERIAL PROPERTIES

### PHYSICAL PROPERTIES

Property	Result	Unit	Standard applied
Raw density	2.24	g/cm <sup>3</sup>	DIN EN ISO 10545-3
Weight	65	kg/m <sup>2</sup>	
Scratch hardness	6	Mohs scale	DIN EN 15771
Crazing resistance	no crazing		DIN EN ISO 10545-11
Wear	Class 4		DIN EN ISO 10545-7

### MECHANICAL PROPERTIES

Property	Result	Unit	Standard applied
Cold compression strength	159	MPa	DIN EN 993-5
Bending strength	42.1	N/mm <sup>2</sup>	DIN EN ISO 10545-4
Static modulus of elasticity	39	GPa	DIN EN 993-6

### THERMAL PROPERTIES

Property	Result	Unit	Standard applied
Fire load	non-flammable, Euroclass A1		DIN EN 13501-1
Thermal conductivity	1.57	W/mK	DIN EN 821-2
Thermal expansion	$\left( \begin{array}{l} 25-400 \\ 25-800 \end{array} \right) \begin{array}{l} 5.6 \cdot 10^{-6} \\ 5.9 \cdot 10^{-6} \end{array}$	K <sup>-1</sup>	DIN 51045-2
Application temperature	up to 550 °C, temporary exposure up to 800 °C		

### CHEMICAL RESISTANCE

Property	Result	Description	Standard applied
<b>Resistance to testing solutions</b> (e.g. solution of hydrochloric acid and sodium hypochloride)	No visible effect on the test specimens.	Test samples made of FRIDURIT Technical Ceramics are exposed to testing solutions. The samples are examined visually after a specific period of time.	DIN EN ISO 10545-13
<b>Resistance to staining</b> (e.g. chrome green)	Stains can be completely removed with hot water (Class 5).		DIN EN ISO 10545-14

### OPTICAL PROPERTIES

Silk finish surface in the current glaze colours. Other colours are available to special order. Colour samples are available on request.

## QUALITY GUIDELINES

Before leaving our factory all our products are subjected to stringent controls in order to ensure the same high standards of quality. Just like wood or leather products, which are much appreciated for their individual grain and texture, FRIDURIT laboratory benchtops made of Technical Ceramics may show optical irregularities. Natural variations in colour and appearance on the same product and between the various benchtops are typical for the material and are unavoidable due to the complex manufacturing process. In addition, dimensional tolerances as a result of material properties may arise (see DIN 12916).

The features indicated do not affect quality and thus do not constitute any defects. Far more, they belong to the characteristic properties of the material.

## CLEANING

The high density of the material results in easy-to-clean, permanently sealed surfaces. We recommend cleaning the FRIDURIT benchtops with a sponge or cloth using traditional cleaning agents such as those used in bathrooms. Stubborn dirt can be removed using an abrasive sponge suitable for glass ceramics.

We will be pleased to answer any questions you may have.



**KYOCERA Fin ceramics Solutions GmbH**

Steinzeugstraße 92  
68229 Mannheim / Germany  
Tel.: +49 (0) 621 - 405 47 400  
E-Mail: [info@kyocera-solutions.de](mailto:info@kyocera-solutions.de)  
[www.kyocera-solutions.de](http://www.kyocera-solutions.de)

European Headquarters:

**KYOCERA Europe GmbH**

Fritz-Mueller-Strasse 27  
73730 Esslingen / Germany  
Tel.: +49 (0)711 - 93 93 4-0  
E-Mail: [info.fc@kyocera.de](mailto:info.fc@kyocera.de)  
[www.kyocera.eu](http://www.kyocera.eu)